

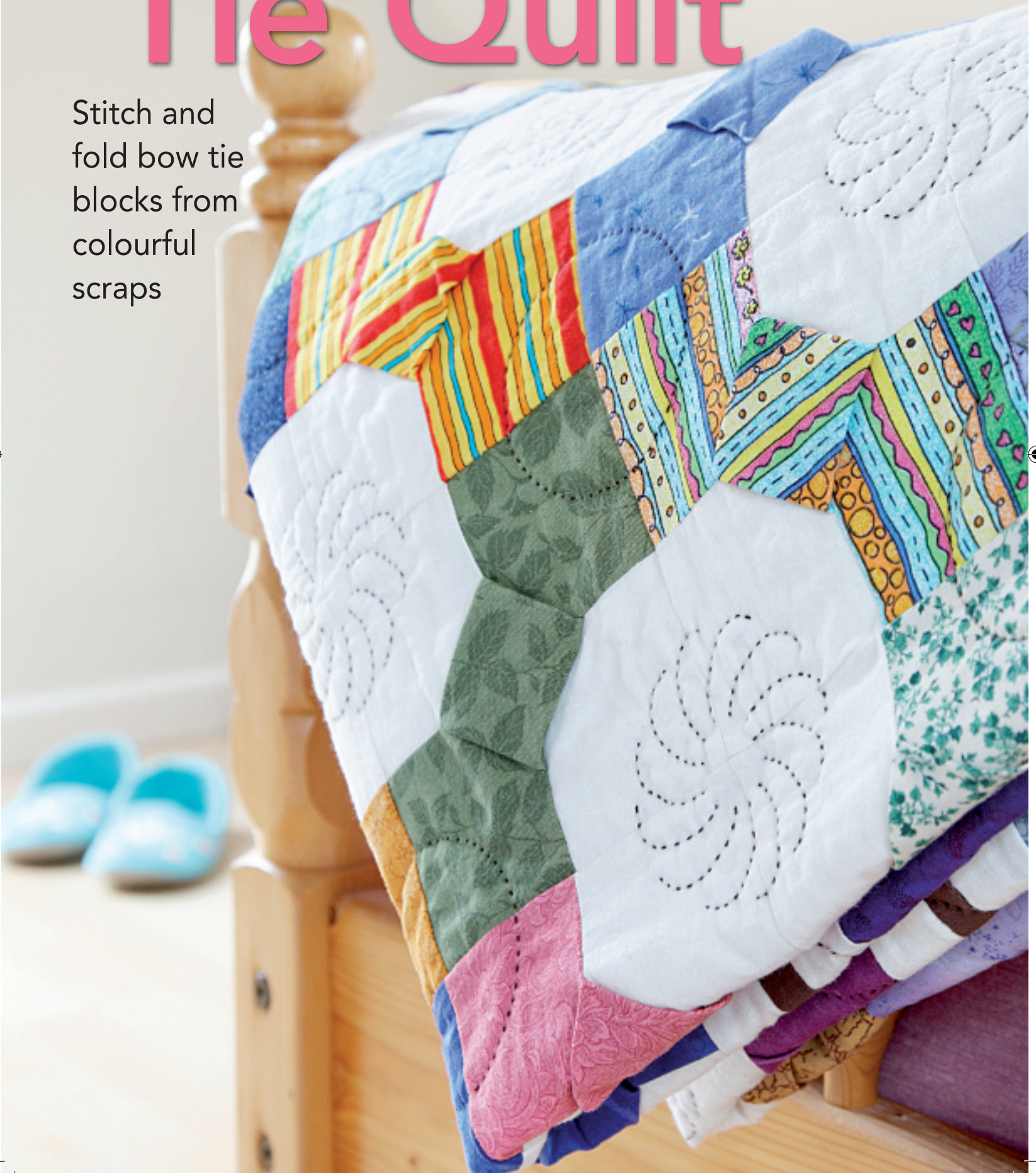

3D Bow Tie Quilt

See pattern
sheet for
template

Stitch and
fold bow tie
blocks from
colourful
scraps



This is a fun quilt you can make block by block with fabrics you already have, or can perhaps collect over time. It would be a great memory quilt idea for offcuts from dressmaking or children's clothes - even old ties! Sheila made two of these quilts for her sisters, who were both celebrating 50th wedding anniversaries. What a wonderful gift!

CUTTING INSTRUCTIONS

1 Cut 243 3in squares from the assorted fabrics. You will need three squares from each of the 81 assorted fabrics, to make 81 different bow tie blocks.

2 Cut 44 5⁷/₈in squares from the assorted fabrics for the border triangles. Cut four 6¹/₄in squares for the corner blocks.

3 Cut 162 3in squares from calico or plain background fabric. You will need two background squares for each bow tie block.

4 Cut 44 5⁷/₈in squares from the calico or plain background fabric for the border triangles. Cut four 6¹/₄in squares for the quarter square triangle blocks.

5 Cut ten strips of calico or plain background fabric 1¹/₂in wide, across the fabric width, for the first and third borders of narrow sashing.

6 Cut five strips of contrast fabric 3³/₄in wide, across the fabric width, for the second border of narrow sashing.

7 Cut seven strips of contrast fabric 2¹/₂in wide, across the fabric width, for the binding.

MAKE THE BOW TIE BLOCKS

1 Take three 3in squares of coloured fabric for the bow tie and two 3in squares of plain background fabric. Fold one coloured square in half, right sides out, for the 'knot'.

2 Place the folded knot on the right side of a background fabric square, matching the raw edges along the top as in Fig 1.

3 Lay a bow tie fabric square on top of this pair, right side down. Sew a 1/4in seam down the left side of the unit, seam A, as shown in Fig 2.

Handy hint

If you prefer, you can make the bow tie 'knot' from a contrast fabric.

Skill level



Finished size

Approx 153 x 153cm (60 x 60in)

Materials

- ◆ 81 15in squares of assorted cotton fabrics, for bow ties and half square triangles
- ◆ 3m (3¹/₄yds) calico or plain fabric for background
- ◆ 60 cm (3/4yd) contrast fabric for sashing and binding
- ◆ 3.3m (3⁵/₈yds) backing fabric
- ◆ 163 x 163cm (64 x 64in) wadding
- ◆ Scraps of wadding for padding the 'knots' (optional)
- ◆ Sewing and quilting threads

Where to buy

Raid your scrap bag and stash or buy mixed bundles from quilt shops. See our advertisers for mail order services.

Preparation

All measurements include 1/4in seam allowances, unless otherwise stated. Wash and press all fabrics before cutting out.

Designed and made by Sheila Goodwin, as taught by Stephanie Pettengell

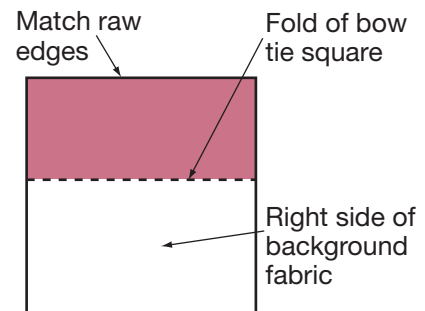

Fig 1 Place folded bow tie knot on a background square

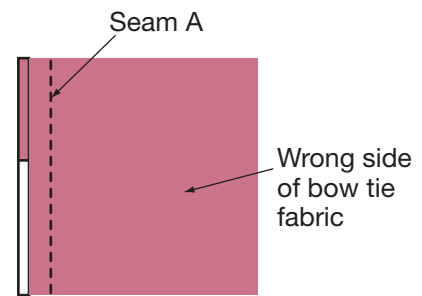

Fig 2 Place bow tie fabric on top, match raw edges



Fig 3 Turn back the unfolded squares. The first stage should look like this

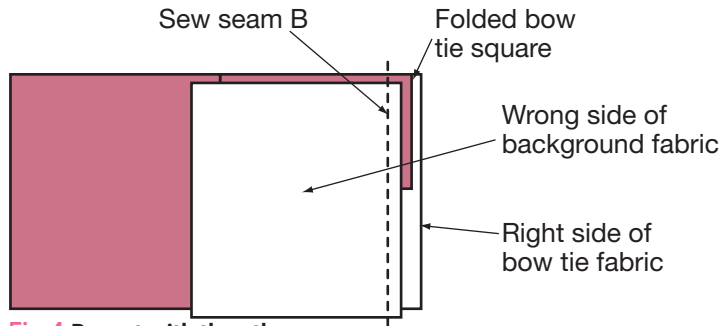
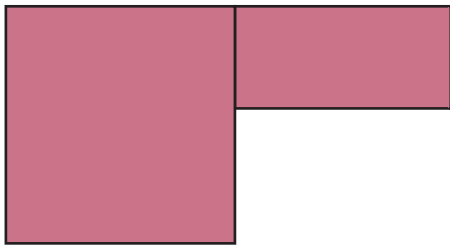

Fig 4 Repeat with the other side of the knot. Sew seam B

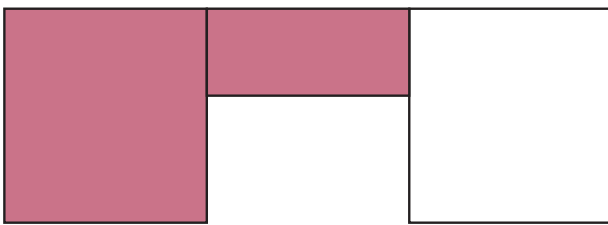

Fig 5 Unit with folded square inside and seams meeting in the centre

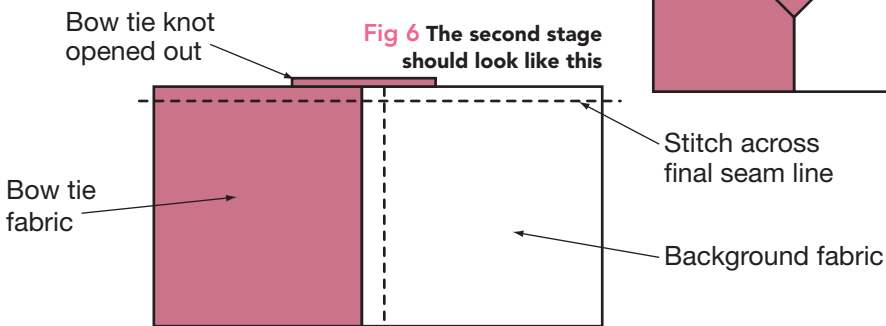
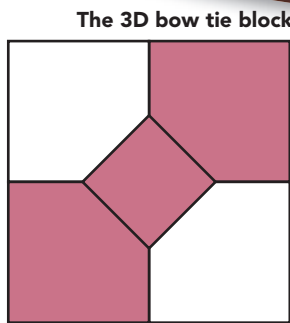

Fig 6 The second stage should look like this



4 Fold back the squares to reveal the folded knot and press. See Fig 3. Place a bow tie square under the knot and a background square on top of the knot, matching the raw edges on the right side of the unit, as in Fig 4.

5 Sew a 1/4in seam down the right side of the unit, seam B, as shown in Fig 4. When this unit is opened out it should look like Fig 5. Press carefully.

6 Open the pocket formed by the 'knot square'. Gently pull it right out so that the raw edges of the pocket

line up with the edges of the bow tie background squares. If you wish, the knot can be padded by inserting a thin piece of wadding behind the 'knot' square.

7 Ensure that the centre seams match up as in Fig 6. Pin in place. Sew carefully across the top of the unit with a 1/4in seam allowance as shown. Take care to ensure that the pocket edges are sewn in and that there are no extra tucks.

8 Open out the block, flattening the 'knot' into place. Press the block and trim. Do not press the knot if you have

padded it. Each finished bow tie block should measure 5in square.

ASSEMBLING THE BLOCKS

1 Lay the blocks out in a pleasing arrangement, using the picture and quilt layout guide in Fig 7 to help you. Sheila used lighter bow ties across the middle of the centre panel, becoming gradually darker towards the top and bottom.

2 Join the blocks into nine rows, with nine blocks in each row, pressing the seams in alternate directions across the row. Join the rows to form a 45 x 45in square centre panel. Press carefully, avoiding the padded knots.

SASHING BORDERS

1 Sew a 1 1/2in calico or plain background fabric strip to each side of the centre panel, piecing the strips as necessary. Trim to size. Sew a 1 1/2in calico fabric strip to the top and bottom of the centre panel, piecing as required and trim.

2 Next, sew a 3/4in contrast fabric strip to the sides of the centre panel, piecing as before and trim. Add a 3/4in contrast fabric strip to the top and bottom of the centre panel, piecing as required. Trim to size.





QUILTING AND FINISHING

- 1** Press the quilt top and backing fabric. Piece the backing fabric to make a 64in square. Lay the backing fabric right side down. Place the wadding on top. Place the finished quilt top right side up on the wadding.
- 2** Tack or pin the layers together using quilters' safety pins, working from the centre out. Quilt in the ditch around the bow ties to accentuate them if you wish. Quilt $3\frac{1}{2}$ in diameter circles where the bow ties meet, as shown in the picture.
- 3** Using the quilting suggestion on the Pattern Sheet, quilt a $3\frac{1}{2}$ in diameter swirling flower shape in the plain fabric 'octagons' formed by the bow tie shapes.
- 4** Quilt zigzags from side to side across the sashing borders. Quilt $3\frac{1}{2}$ in diameter circles in the half square triangle blocks, as shown in Fig 7.
- 5** Trim the wadding and backing to the same size as the finished quilt top. Join the contrast binding fabric with diagonal seams, to create a strip about 7yds long.



- 6** Fold the binding in half, wrong sides together, and press along the length. With right sides together, pin the binding to the edges of the quilt, placing the long raw edge of the binding along the raw edges of the quilt top.
- 7** Stitch the binding in place with a $\frac{1}{4}$ in seam. Trim the ends and tuck under. Fold the binding over to the back of the quilt and slipstitch neatly in place. Add a label with your name and date. ♦

- 3** Add $1\frac{1}{2}$ in strips of calico fabric to each side of the centre panel and trim. Sew a $1\frac{1}{2}$ in calico strip to the top and bottom of the centre panel and trim, as before.

BORDER TRIANGLES

- 1** Place two $5\frac{7}{8}$ in squares, one bright and one calico RS together. Mark a diagonal line on the calico, and stitch $\frac{1}{4}$ in either side of it. Cut across the marked line and press towards the darker fabric, repeat for all the triangles needed.
- 2** Repeat step 1 above using $6\frac{1}{4}$ in squares for quarter square triangles. Place two pairs of half square triangles together with the calico triangle against a bright. Draw the opposite diagonal and repeat the sewing and cutting process.
- 3** Join the half square triangles together into four strips of ten. Add quarter square triangles to the ends of two strips.
- 4** Sew the strips of ten triangles to opposite sides of the quilt top. Sew the remaining strips to the top and bottom.

Fig 7 Quilt layout diagram

